



135 Series

300lbs Electromagnetic Lock

Model **UL135-S (Unmonitored Version)**



Description

300lbs EM locks were designed to meet fire/life safety applications by providing an auxiliary locking mechanism that has no moving parts to bind or wear out for trouble free operation. This will ensure inhibited release at all times where they have become extremely prevalent in applications other than fire/life safety. Suitable for access controlled & small enclosure.

Standard Features



Life Safety Application



No Residual



Low Energy Consumption



Cost Saving

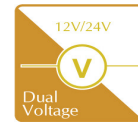

12/24V Non-Selectable



Ideal for all door types

Extended Features

(Optional)

- Electroless Nickel (EN) Plated Armature Plate
- Anodized Aluminium Housing
- CE Compliance

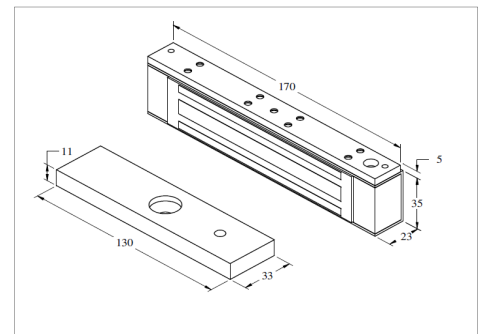

Specification

	UL135-S
Magnet Size	170 X 35 X 23 mm
Armature Size	130 X 33 X 11 mm
Holding Force	Up to 300lbs
Current Drain	300mA±10%/12Vdc / 150mA±10%/24Vdc
Temperature	(-10 to 55)°C (14 to 131)°F
Weight	1.5kg

WARRANTY:- Algatec EM Lock are warranted against defects in material and workmanship while used in normal service for a period of 5 years from the date of sale to the original customer.

DISCLAIMER:- Specifications are subject to change without prior notice.

- Attached photo is for reference purpose only, actual product may varies.

