



ELECTROMAGNETIC LOCK PRODUCTS



275 Series

600lbs Electromagnetic Lock with LED Lens

Model **UL275-SK (Monitored Version)**



Description

600lbs EM locks were designed to meet fire/life safety applications by providing an auxiliary locking mechanism that has no moving parts to bind or wear out for trouble free operation. This will ensure inhibited release at all times where they have become extremely prevalent in applications other than fire/life safety. Suitable for access controlled & secure areas within buildings.

Standard Features



Life Safety Applications



No Residual



Low Energy Consumption



Cost Savings

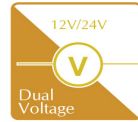

12/24V Selectable



Ideal for all door type

Extended Features

(Optional)

- Additional feature with **LED Lens** to ease the monitoring of Lock Status.
- Lock Status Monitoring
- Electroless Nickel (EN) Plated Armature Plate
- Anodized Aluminium Housing
- CE Compliance

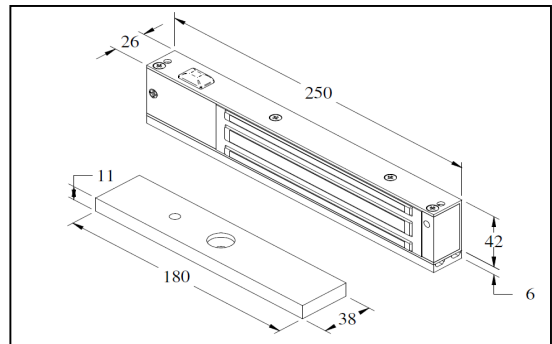

Specification

	UL275-SK
Magnet Size	250 X 42 X 26 mm
Armature Size	180 X 38 X 11 mm
Holding Force	Up to 600lbs
Current Drain	480mA±10%/12Vdc / 240mA±10%/24Vdc
Temperature	(-10 to 55)°C (14 to 131)°F
Weight	2.0kg

Wiring Diagram

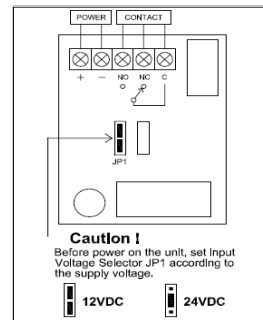

WARRANTY:- Algatec EM Lock are warranted against defects in material and workmanship while used in normal service for a period of 5 years from the date of sale to the original customer.

DISCLAIMER:- Specifications are subject to change without prior notice.

- Attached photo is for reference purpose only, actual product may varies.

